

Accuphase

INTEGRATED STEREO AMPLIFIER

E-408

● Triple parallel push-pull output stage delivers high power: 180 watts per channel into 8 ohms ● Preamplifier and power amplifier with MCS topology and current feedback ● Logic-control relays permit straight and short signal paths ● Tone control circuits ● Ample power supply with high-capacity R-toroidal transformer ● Option board slots provide capability for digital signal input or analog record playback





High-output, high-performance integrated amplifier – with MCS topology in preamplifier and power amplifier stages. Current feedback ensures optimum phase characteristics in high frequency range. Wide-band power transistors in triple push-pull configuration and high-efficiency R-toroidal power transformer deliver plenty of quality power: 260 watts per channel into 4 ohms or 180 watts into 8 ohms. Option boards can be used to implement digital input or analog record playback with impeccable quality.

The E-408 is a further refined and enhanced version of the highly popular and successful E-407. Incorporating latest technology and using only top quality parts, the E-408 is an integrated amplifier that stands out through sheer excellence. S/N ratio in the preamplifier and power amplifier sections has been further improved by the adoption of MCS (Multiple Circuit Summing). Musical dynamics never sounded so impressive, with every nuance clearly outlined. The E-408 is the yardstick by which integrated amplifiers will be measured from now on.

Because an integrated amplifier has very high overall gain, even the slightest interference or crosstalk at the input can have a considerable effect on the signal provided at the output. To preclude this possibility, the E-408 is built with totally separate preamplifier and power amplifier sections. Both electrically and structurally, these two parts operate completely autonomously. Each has its own power supply and dedicated regulator circuitry. A separate set of inputs and outputs even allows using the preamplifier and power amplifier as if they were stand-alone components.

The circuits in the preamplifier and power amplifier stages both use the MCS principle as well as current feedback. MCS is a sophisticated technique developed by Accuphase for connecting multiple circuits in parallel. The overall result of combining these circuit topologies are improved performance specs as well as superior sound quality. The output stage of the power amplifier is constructed as a triple parallel push-pull configuration of multi-emitter type power transistors designed for high-current audio applications. The efficient R-toroidal power transformer in the power supply and plenty of filtering capacity support 260 watts per channel (4 ohms) or 180 watts (8 ohms). The preamplifier section features tone controls and a loudness compensator designed to retain the purity of the music signal. Functions such as recorder

monitoring and copying provide welcome flexibility. All major parts were selected by strict listening evaluation to assure a high all-round standard of quality.

A Digital Input Board using a high-precision MDS (Multiple Delta Sigma) D/A converter is available as an option, allowing the digital signal of a CD player or similar to be directly supplied to the E-408. Another option is an Analog Disc Input Board for high-grade reproduction of analog records.

Triple parallel push-pull power unit delivers 260 watts/ch into 4 ohms, 220 watts/ch into 6 ohms, and 180 watts/ch into 8 ohms

The power transistors used in the output stage are multi-emitter devices designed for audio applications, with optimum frequency response, forward-current transfer ratio linearity, and switching performance characteristics. By arranging these devices in a triple parallel configuration (Figure 1), low impedance is

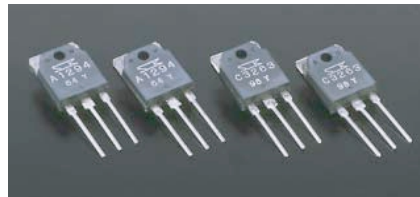

achieved. The transistors are mounted to a large heat sink for efficient dissipation of thermal energy. As a result, the E-408 provides plenty of high-quality output power.

Parallel connection MCS topology in preamplifier and power amplifier stages

Both the power amplifier (Figure 1) and preamplifier (Figure 2) employ the MCS (Multiple Circuit Summing) topology developed by Accuphase. This design results in significantly improved performance characteristics such as higher S/N ratio and lower

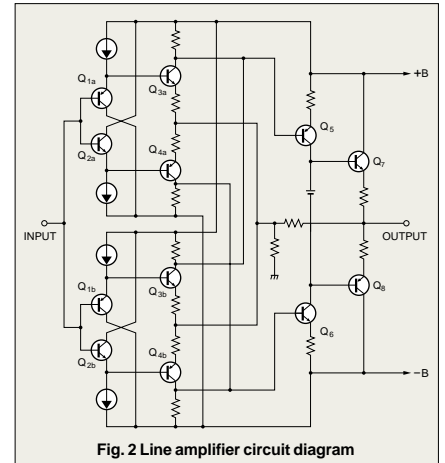
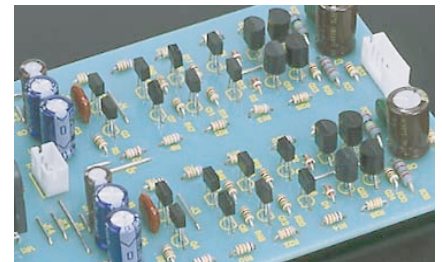

Fig. 2 Line amplifier circuit diagram

distortion. In the E-408, two separate amplification circuits are fed the same signal, as well as the feedback signal, and the output of the circuits is combined, which is equivalent to parallel operation of the overall circuit. Mathematically, when two parallel circuits are employed, the improvement in S/N ratio is 3 dB.



Current feedback circuit topology in power amplifier and preamplifier sections prevents phase shifts

In the E-408, the signal current rather than the more conventionally used voltage is used for feedback.

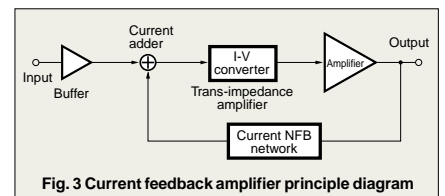

Fig. 3 Current feedback amplifier principle diagram

Because there is almost no phase shift, phase compensation can be kept to a minimum, resulting in excellent transient response and superb sonic transparency. Figure 4 shows frequency response for different gain settings of the current feedback amplifier. The graphs demonstrate that response remains uniform over a wide range.

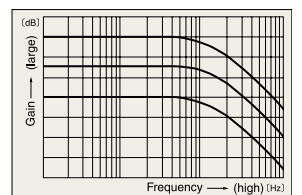

Fig. 4 Frequency response with current feedback (response remains uniform even when gain changes)

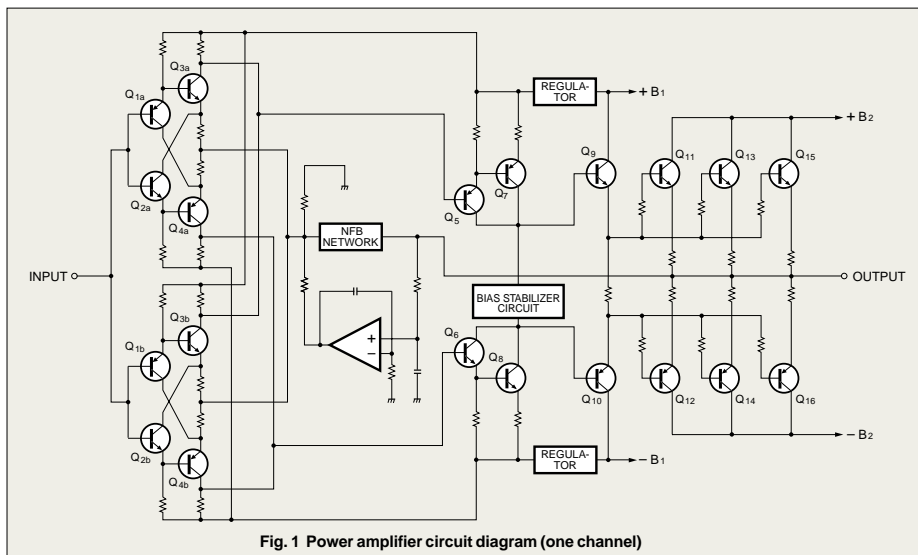

Fig. 1 Power amplifier circuit diagram (one channel)

High-efficiency toroidal power transformer and high filtering capacity

The power supply section is a critical aspect of any power amplifier. The E-408 features a large toroidal power transformer with a rating of 600VA. The transformer is housed in a non-resonant aluminum enclosure filled with damping material that has excellent heat transfer characteristics. Two large 33,000 μ F capacitors smooth out any current irregularities. This no-holds-barred approach manifests itself in rock-solid, powerful sound even at ultra-deep frequencies.



this circuit. The flat signal is passed straight through, and only when an adjustment is required, the characteristics are created at F1 and F2 and added to the signal, thereby producing the desired change. This design provides efficient control without diluting signal purity.

Logic-controlled relays for signal switching assure high sound quality and long-term reliability

All signal switching is performed by logic-controlled relays which are arranged so as to permit the shortest

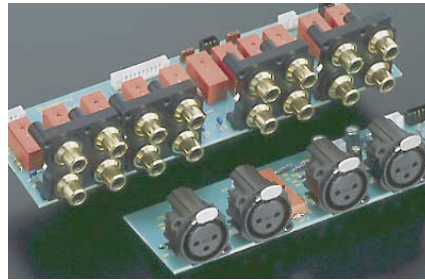

possible signal paths. The hermetically sealed relays are high-quality types developed specifically for demanding communication applications. The contacts are twin crossbar types plated with gold for minimum contact resistance and outstanding long-term reliability.

Two sets of large size speaker terminals

The speaker terminals are made of extruded high-purity brass material which accept also heavy-gauge speaker cable. Two sets of outputs with a speaker selector are provided, and bi-wiring (supplying the same signal via dual leads to speakers with separate high-frequency and low-frequency inputs) is also possible.

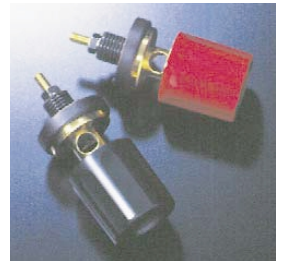

Tone controls with summing active filters for best sound

The tone control circuitry in the E-408 was specially designed with summing active filters such as found in high-quality graphic equalizers. Figure 5 illustrates the operation principle of

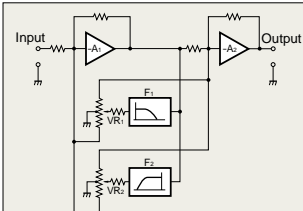
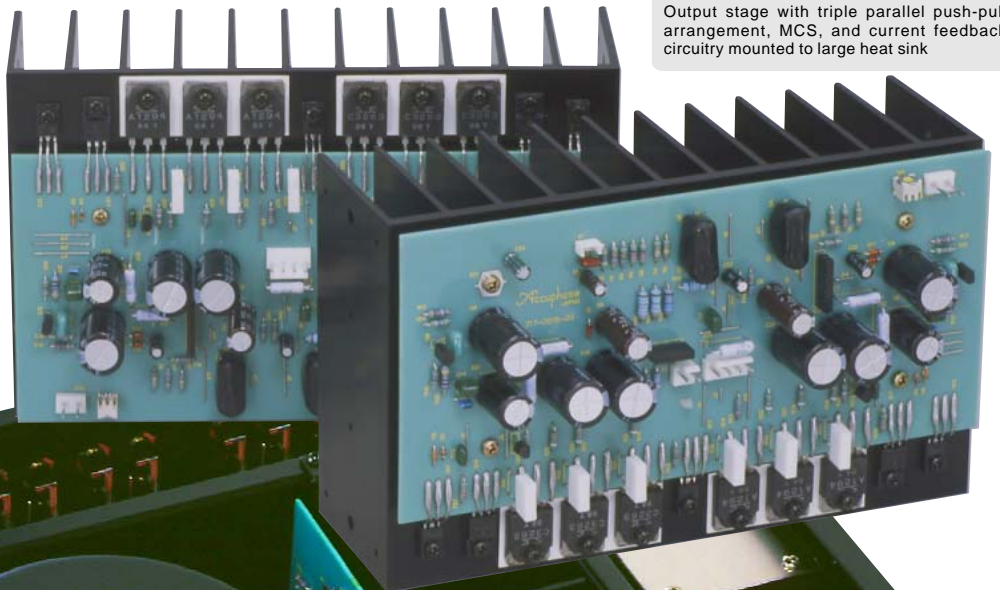

Fig. 5 Tone control principle (Summing active filter type)



Output stage with triple parallel push-pull arrangement, MCS, and current feedback circuitry mounted to large heat sink



Supplied remote commander RC-20 allows volume adjustment and input source switching

Other Functions and Features

- Digital input can be implemented via option board.
- Analog power meters
- High-quality volume control that can also be operated via supplied remote commander
- "High Carbon" cast iron insulator feet with superior damping characteristics further enhance sound quality
- Dedicated headphone amplifier for optimum sound
- EXT PRE button and dedicated inputs/outputs enable independent use of preamplifier and power amplifier sections
- Loudness compensator restores natural balance at low listening levels

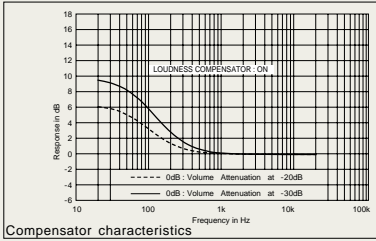

OPTION BOARDS

Three types of option boards are available for the E-408: Digital Input Board DAC-10, Analog Disc Input Board AD-10, and Line Input Board LINE-10.

- Two identical boards can also be installed.
- The Analog Disc Input Board AD-9 and Line Input Board LINE-9 can also be used.
- The DAC-10 cannot be used in the models E-407, E-406V, E-306V, E-211, and C-265.

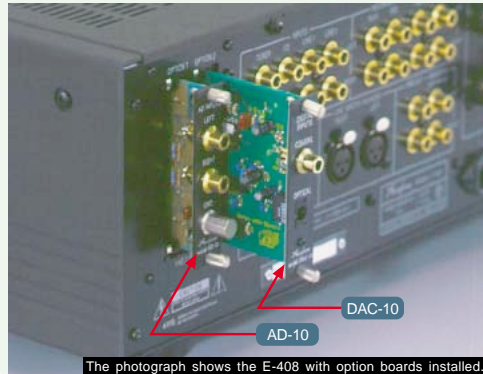

Digital Input Board DAC-10

This board features an MDS (Multiple Delta Sigma) D/A converter and has inputs for coaxial and optical fiber connections.

It can accept the digital output signal from components such as a CD player, MD recorder, DAT recorder, etc. (sampling frequency range 32 - 96 kHz, 24 bits).

Analog Disc Input Board AD-10

This board contains a high-performance, high-gain phono equalizer.

● Internal DIP switches control MM/MC operation, MC input impedance, and subsonic filter on/off.

MM	Gain	: 36 dB
	Input impedance	: 47 kΩ
MC	Gain	: 62 dB
	Input impedance	: 10/30/100 Ω (selectable)

Line Input Board LINE-10

This option board provides an additional set of conventional line inputs which can be used to connect a CD player, tuner, or other component with analog output.

Front panel

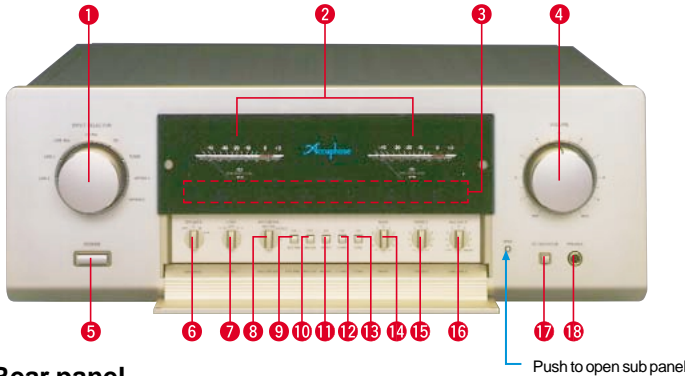

Rear panel

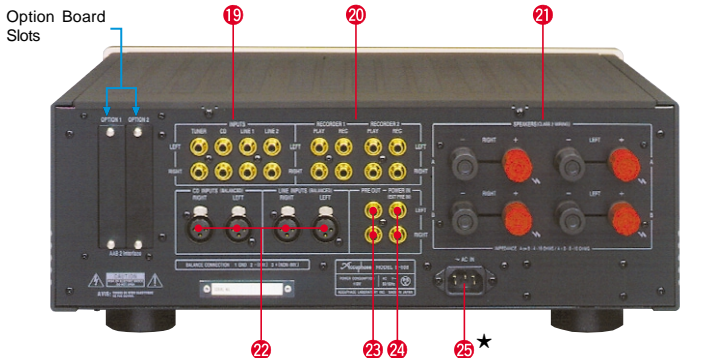

- | | |
|---|--|
| <p>1 Input Selector
LINE2 LINE1 LINE-BAL CD-BAL
CD TUNER OPTION 1 OPTION 2</p> <p>2 Right/Left Channel Power Meters (dB scale/% indication)</p> <p>3 Function LED Indicators</p> <p>4 Volume Control</p> <p>5 Power Switch</p> <p>6 Speaker Selector OFF A B A+B</p> <p>7 Copy Selector 1→2 OFF 2→1</p> <p>8 Recorder Selector REC OFF SOURCE 1 2</p> <p>9 EXT PRE (Preamplifier/Power Amplifier Separator) ON/OFF Button</p> <p>10 Meter Operation/Light Button</p> <p>11 Stereo/Mono Button</p> | <p>12 Loudness Compensator Button</p> <p>13 Tone Control ON/OFF Button</p> <p>14 Bass Control</p> <p>15 Treble Control</p> <p>16 Balance Control</p> <p>17 Attenuator Button</p> <p>18 Headphone Jack</p> <p>19 Line Input Connectors</p> <p>20 Recorder Rec/Play Connectors</p> <p>21 Left/Right Speaker Outputs</p> <p>22 CD/LINE Balanced Input Connector</p> <p>23 Preamplifier Output Connector</p> <p>24 Power Amplifier Input Connectors</p> <p>25 AC Power Supply Connector*</p> |
|---|--|

Remarks

- * This product is available in versions for 120/230 V AC. Make sure that the voltage shown on the rear panel matches the AC line voltage in your area.
- * The shape of the AC inlet and plug of the supplied power cord depends on the voltage rating and destination country.

- Supplied accessories:
- AC power cord
 - Remote commander RC-20

GUARANTEED SPECIFICATIONS

[Guaranteed specifications are measured according to EIA standard RS-490.]

- **Continuous Average Output Power** (both channels driven, 20 - 20,000 Hz)
260 watts per channel into 4 ohms
220 watts per channel into 6 ohms
180 watts per channel into 8 ohms
 - **Total Harmonic Distortion** (both channels driven, 20 - 20,000 Hz)
0.02%, with 4 to 16 ohms load
 - **Intermodulation Distortion** 0.01%
 - **Frequency Response** HIGH LEVEL INPUT/MAIN INPUT
20 - 20,000 Hz 0, -0.2 dB (for rated continuous average output)
2 - 150,000 Hz 0, -3.0 dB (for 1-watt output)
 - **Damping Factor** 120 (with 8-ohm load, 50 Hz)
 - **Input Sensitivity, Input Impedance**
- | Input | Sensitivity | | Input impedance |
|------------------|------------------|----------------------|-----------------|
| | For rated output | For 1 W output (EIA) | |
| HIGH LEVEL INPUT | 158 mV | 11.2 mV | 20 kΩ |
| BALANCED INPUT | 158 mV | 11.2 mV | 40 kΩ |
| MAIN INPUT | 1.58 V | 112 mV | 20 kΩ |
- **Output Voltage, Output Impedance** PRE OUTPUT: 1.58 V, 50 ohms (at rated continuous average output)
 - **Gain** HIGH LEVEL INPUT → PRE OUTPUT: 20 dB
MAIN INPUT → OUTPUT: 28 dB
 - **Tone Controls** Turnover frequency and adjustment range
BASS: 300 Hz ±10 dB (50 Hz)
TREBLE: 3 kHz ±10 dB (20 kHz)
 - **Loudness Compensation** +6 dB (100 Hz) (Volume control setting -30 dB)
 - **Attenuator** -20 dB
 - **Signal-to-Noise Ratio**
- | Input | Input shorted (A weighting) | | EIA S/N |
|------------------|-----------------------------|--|---------|
| | S/N ratio at rated output | | |
| HIGH LEVEL INPUT | 113 dB | | 82 dB |
| BALANCED INPUT | 92 dB | | 82 dB |
| MAIN INPUT | 129 dB | | 103 dB |

- **Power Level Meters** Logarithmic compression, peak reading meters
Output dB/% scale
- **Load Impedance** 4 - 16 ohms
- **Stereo Headphones** Suitable impedance: 8 - 100 ohms
- **Power Requirements** AC 120 V, 230 V (Voltage as indicated on rear panel) 50/60 Hz
- **Power Consumption** 55 watts idle
460 watts in accordance with IEC-65
- **Maximum Dimensions** Width 475 mm (18-11/16")
Height 180 mm (7-1/16")
Depth 422.7 mm (16-5/8")
- **Weight** 23.4 kg (51.6 lbs) net
28.0 kg (61.7 lbs) in shipping carton
- **Supplied Remote Commander RC-20**
Remote control principle: infrared pulse
Power supply: 3 V DC (IEC R6 batteries x 2)
Maximum dimensions: 55 mm x 194 mm x 18 mm
Weight: 100 g (including batteries)